

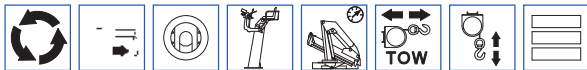

STANDARD



OPTIONAL



Momento statico massimo al perno torretta Max. static moment at the turret pin Moment statique max. a l'axe de la tourelle Max. statisches ubmoment am kransaulenbolzen daN*m (lb*ft)	Coppia di rotazione Slew torque Moment de rotation Drehmoment daN*m (lb*ft)	Uscita stabilizzatori Outriggers extension Sortie de bequilles Breite der Abstutzung mm (ft)	Larghezza stabilizzatori Outriggers width Largeur des bequilles Gesamtbreite der Abstutzung mm (ft)	Pressione Pressure Pression Druck bar (psi)	Capacità serbatoio olio Oil tank capacity Capacité du réservoir de l'huile Öl tank inhalt L (us gal)
90910 (657679)	7000 (50640)	1440+1440 (4' 9"+ 4' 9") 990+990 (3' 3"+ 3' 3")	5280 (17' 4")	240 (3412)	200 (52)

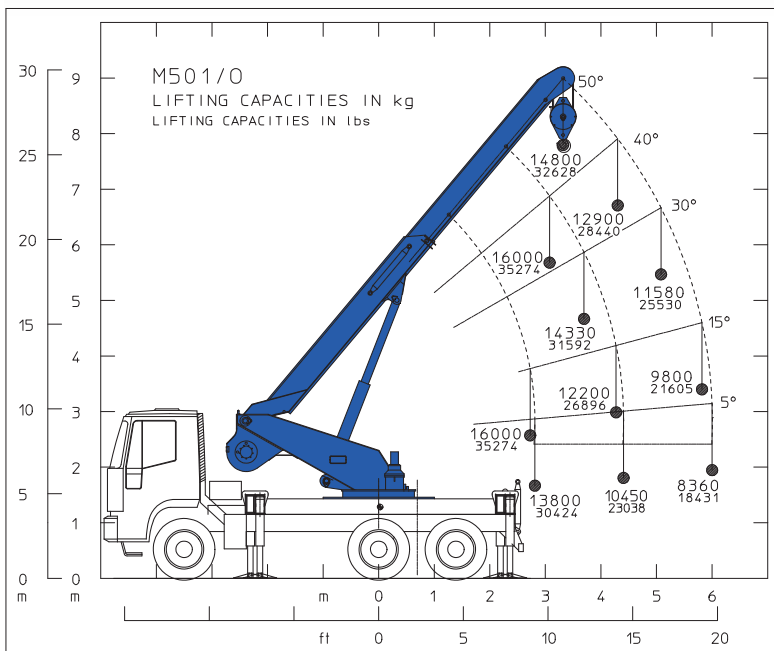

	M501/O
Sbraccio idraulico / Hydraulic boom length / Longueur du bras hydraulique / Hydraulic reichweite	m (ft) 6.00 (19' 8")
Peso (senza olio e montaggio) / Weight (without oil and fitting) / Poids (sans huile et montage) / Gewicht (ohne Öl und ohne)	Kg (lbs) 8200 (18078)